

NC Contact West Panel Loco Lead	3,6
NO Contact West Panel Loco Lead	3,6
NC Contact West Panel Loco Track 1	3,6
NO Contact West Panel Loco Track 1	3,6
NC Contact West Panel Loco Track 2	3,6
NO Contact West Panel Loco Track 2	3,6
NC Contact West Panel Yard Track 1	3,6
NO Contact West Panel Yard Track 1	3,6
NC Contact West Panel Yard Track 2	3,6
NO Contact West Panel Yard Track 2	3,6
NC Contact West Panel Yard Track 3	3,6
NO Contact West Panel Yard Track 3	3,6
NC Contact West Panel Yard Track 4	3,6
NO Contact West Panel Yard Track 4	3,6
NC Contact West Panel Yard Track 5	3,6
NO Contact West Panel Yard Track 5	3,6

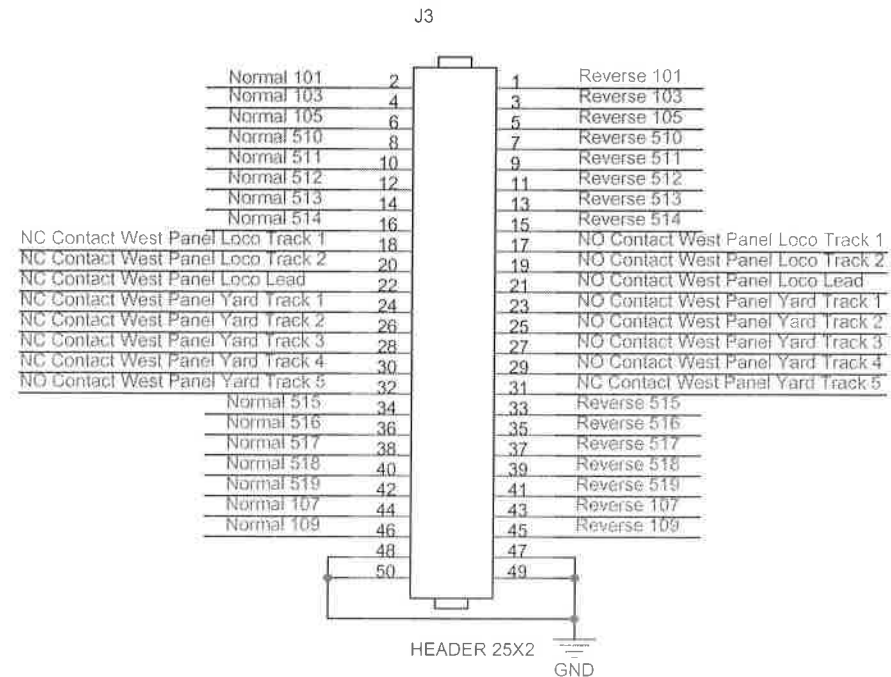

Normal 101	1,3,4
Reverse 101	1,3,4
Normal 103	1,3,4
Reverse 103	1,3,4
Normal 105	1,3,4
Reverse 105	1,3,4
Normal 107	1,3,4
Reverse 107	1,3,4
Normal 109	1,3,4
Reverse 109	1,3,4
Normal 510	1,3,4
Reverse 510	1,3,4
Normal 511	1,3,4
Reverse 511	1,3,4
Normal 512	1,3,4
Reverse 512	1,3,4
Normal 513	1,3,4
Reverse 513	1,3,4
Normal 514	1,3,4
Reverse 514	1,3,4
Normal 515	1,3,4
Reverse 515	1,3,4
Normal 516	1,3,4
Reverse 516	1,3,4
Normal 517	1,3,4
Reverse 517	1,3,4
Normal 518	1,3,4
Reverse 518	1,3,4
Normal 519	1,3,4
Reverse 519	1,3,4

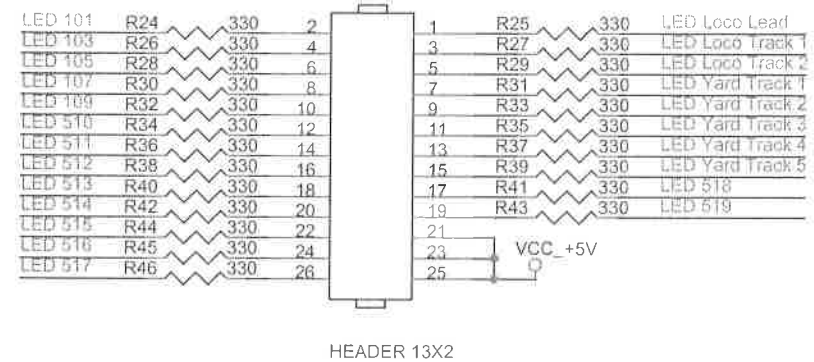

1,3,7,8	LED Loco Lead	LED Loco Lead
1,3,7,8	LED Loco Track 1	LED Loco Track 1
1,3,7,8	LED Loco Track 2	LED Loco Track 2
1,3,7,8	LED Yard Track 1	LED Yard Track 1
1,3,7,8	LED Yard Track 2	LED Yard Track 2
1,3,7,8	LED Yard Track 3	LED Yard Track 3
1,3,7,8	LED Yard Track 4	LED Yard Track 4
1,3,7,8	LED Yard Track 5	LED Yard Track 5
1,3,4,5	LED 101	LED 101
1,3,4,5	LED 103	LED 103
1,3,4,5	LED 105	LED 105
1,3,4,5	LED 107	LED 107
1,3,4,5	LED 109	LED 109
1,3,4,5	LED 510	LED 510
1,3,4,5	LED 511	LED 511
1,3,4,5	LED 512	LED 512
1,3,4,5	LED 513	LED 513
1,3,4,5	LED 514	LED 514
1,3,4,5	LED 515	LED 515
1,3,4,5	LED 516	LED 516
1,3,4,5	LED 517	LED 517
1,3,4,5	LED 518	LED 518
1,3,4,5	LED 519	LED 519

Title		
2 West Panel		
Size	Document Number	Rev
B	Desert Yard Controls	A1
Date:	Friday, October 31, 2003	Sheet 2 of 9

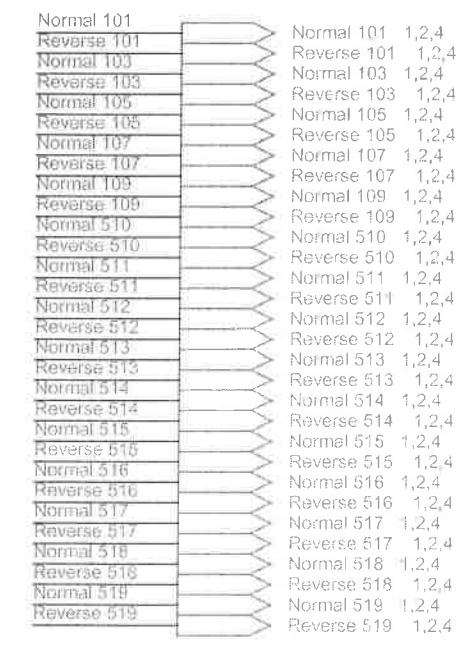
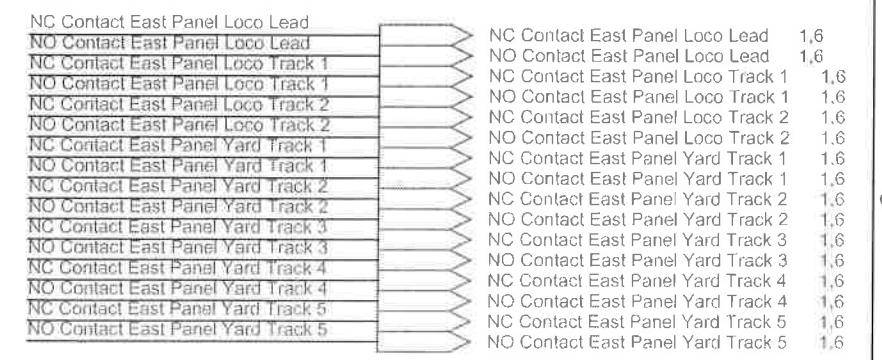
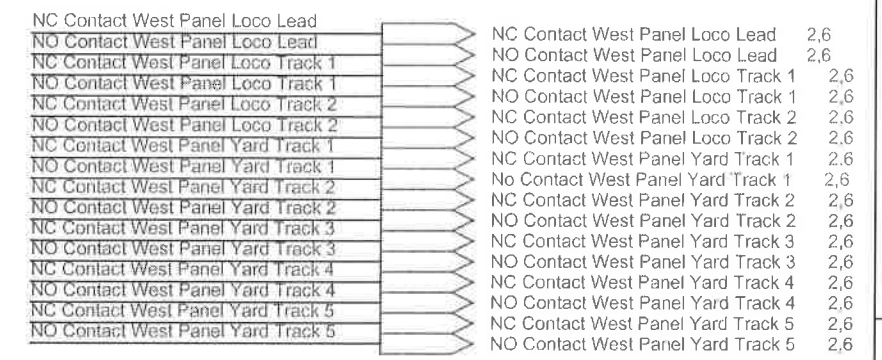
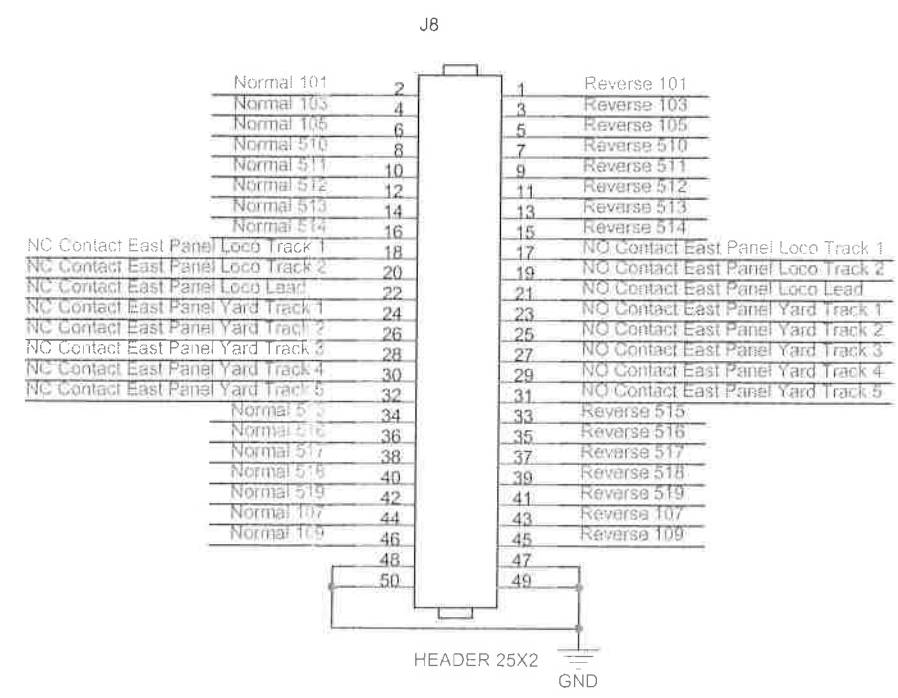
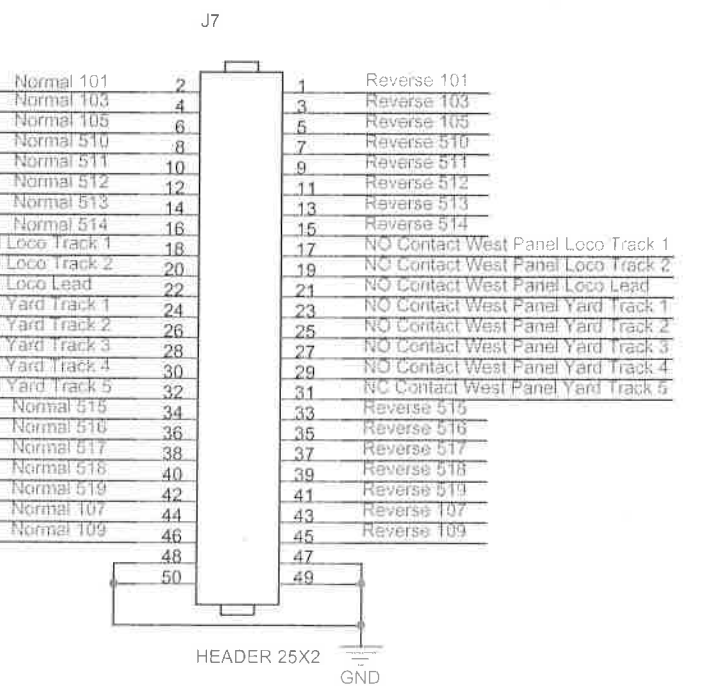
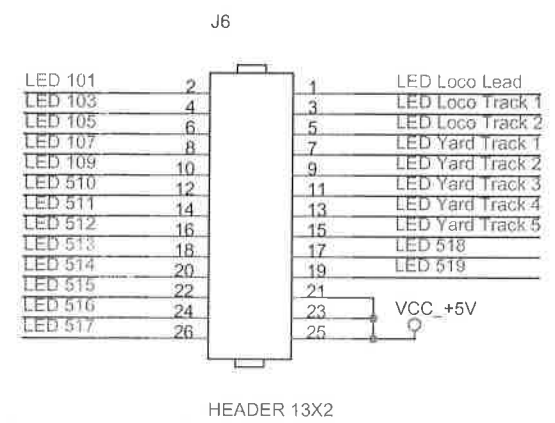
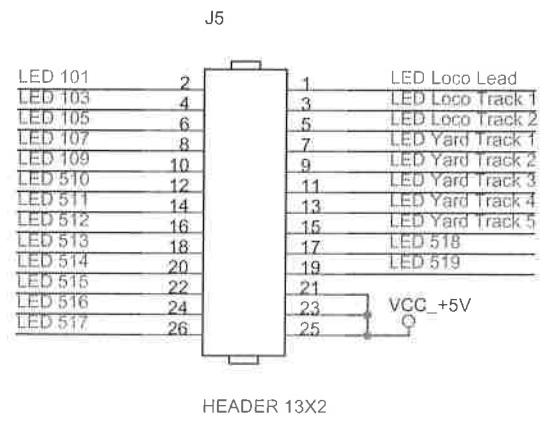
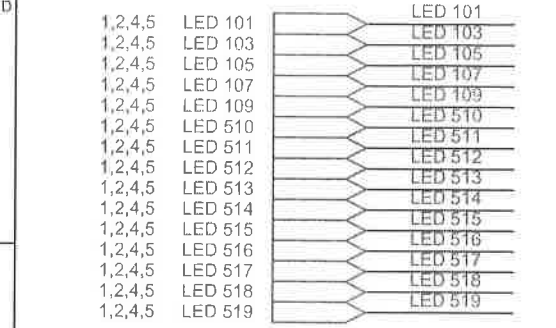
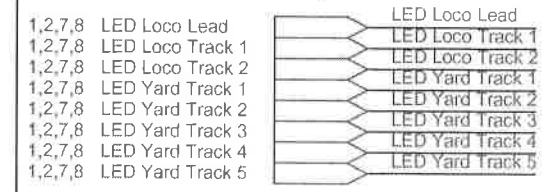

Title		
3 Main Board Headers		
Size	Document Number	Rev
B	Desert Yard Controls	A1
Date:	Friday, October 31, 2003	Sheet 3 of 9



- 1,2,3 Normal 101
- 1,2,3 Reverse 101
- 1,2,3 Normal 103
- 1,2,3 Reverse 103
- 1,2,3 Normal 105
- 1,2,3 Reverse 105
- 1,2,3 Normal 107
- 1,2,3 Reverse 107
- 1,2,3 Normal 109
- 1,2,3 Reverse 109
- 1,2,3 Normal 510
- 1,2,3 Reverse 510
- 1,2,3 Normal 511
- 1,2,3 Reverse 511
- 1,2,3 Normal 512
- 1,2,3 Reverse 512
- 1,2,3 Normal 513
- 1,2,3 Reverse 513
- 1,2,3 Normal 514
- 1,2,3 Reverse 514
- 1,2,3 Normal 515
- 1,2,3 Reverse 515
- 1,2,3 Normal 516
- 1,2,3 Reverse 516
- 1,2,3 Normal 517
- 1,2,3 Reverse 517
- 1,2,3 Normal 518
- 1,2,3 Reverse 518
- 1,2,3 Normal 519
- 1,2,3 Reverse 519
- 1,2,3,5 LED 101
- 1,2,3,5 LED 103
- 1,2,3,5 LED 105
- 1,2,3,5 LED 107
- 1,2,3,5 LED 109
- 1,2,3,5 LED 510
- 1,2,3,5 LED 511
- 1,2,3,5 LED 512
- 1,2,3,5 LED 513
- 1,2,3,5 LED 514
- 1,2,3,5 LED 515
- 1,2,3,5 LED 516
- 1,2,3,5 LED 517
- 1,2,3,5 LED 518
- 1,2,3,5 LED 519

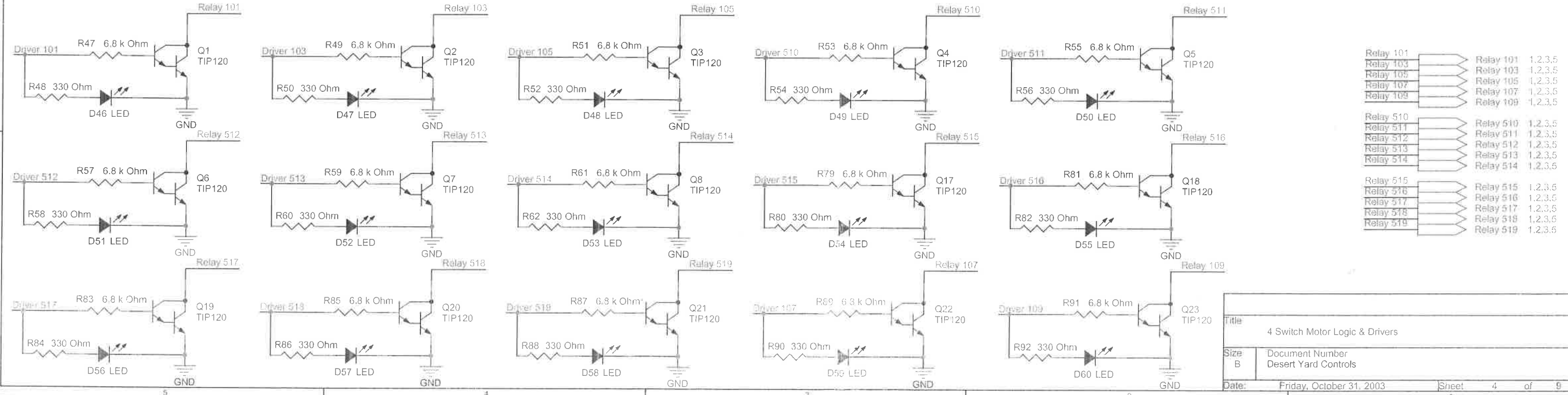
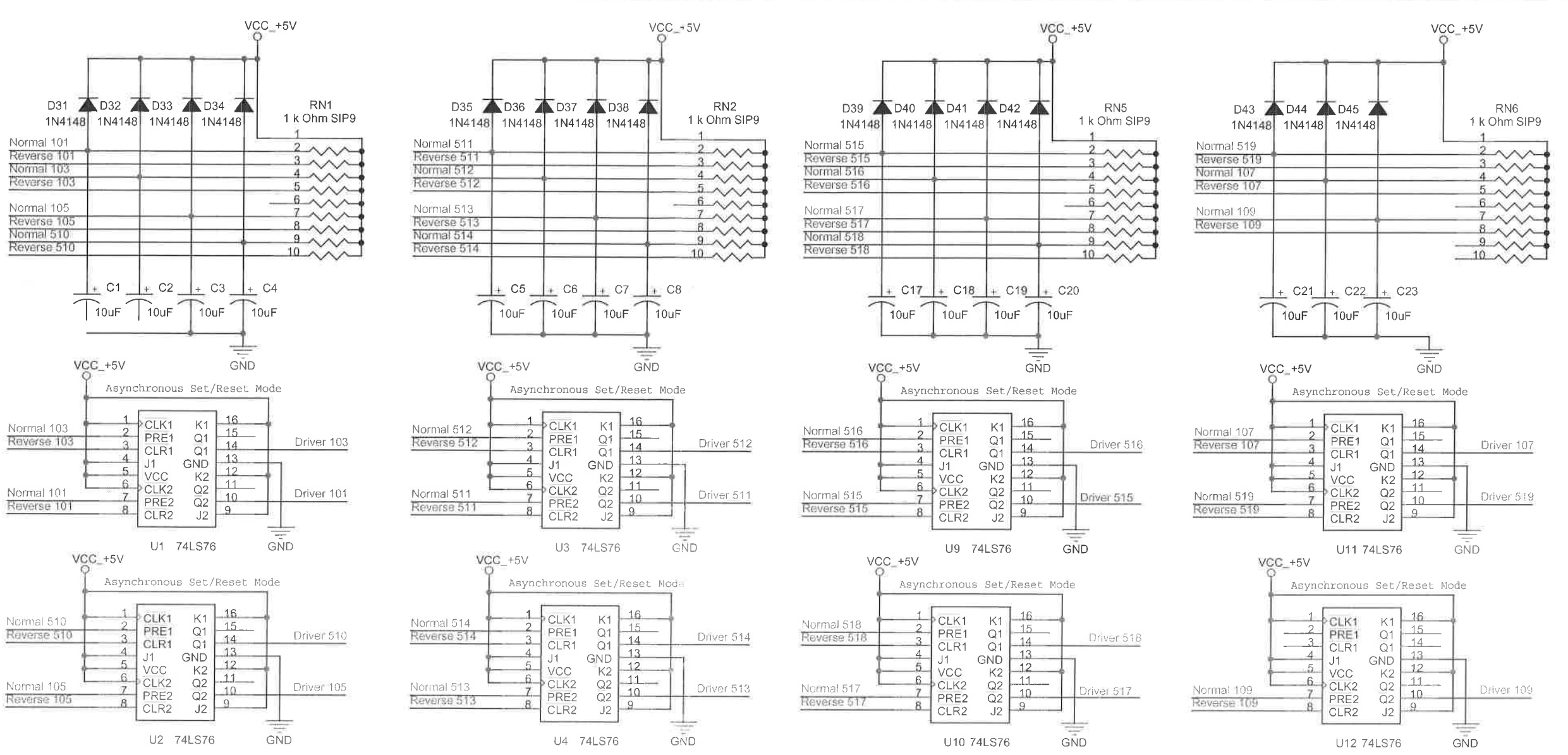

- Relay 101
- Relay 103
- Relay 105
- Relay 107
- Relay 109
- Relay 510
- Relay 511
- Relay 512
- Relay 513
- Relay 514
- Relay 515
- Relay 516
- Relay 517
- Relay 518
- Relay 519

D

1,2,3,4

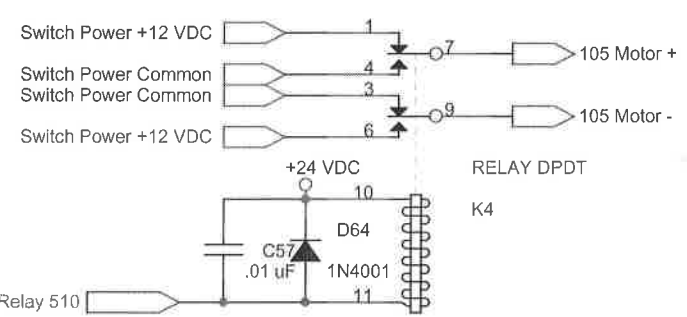
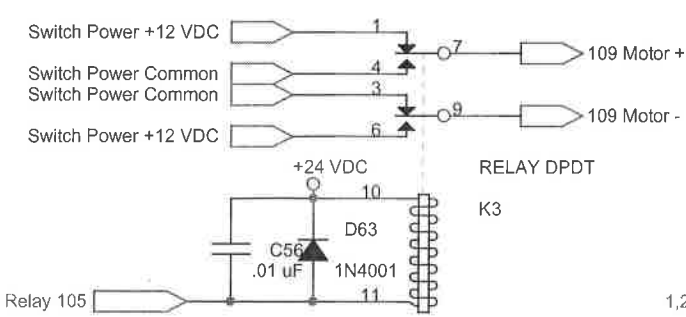
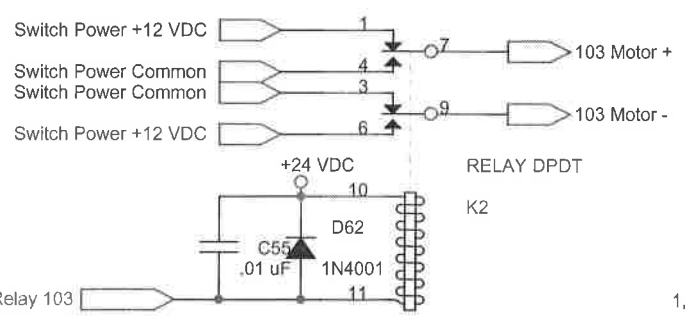
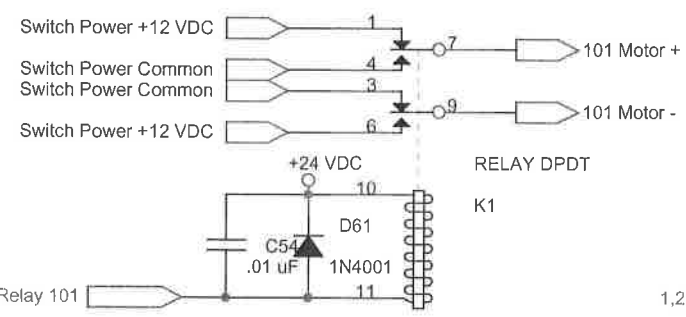

C

1,2,3,4

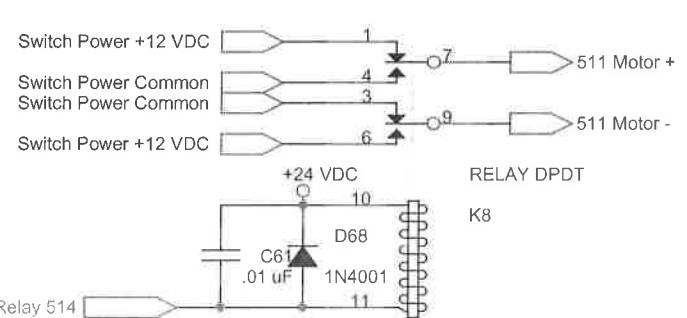
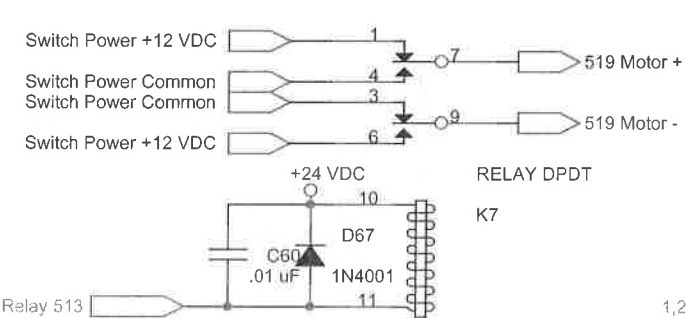
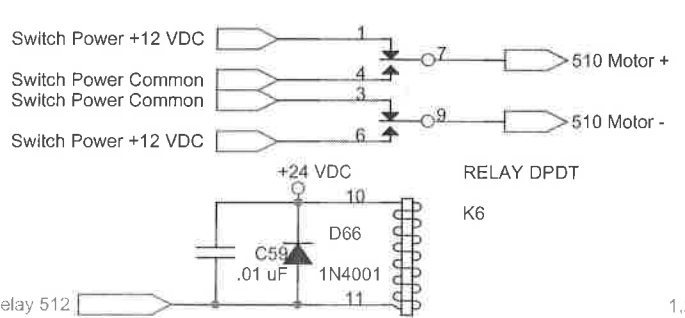
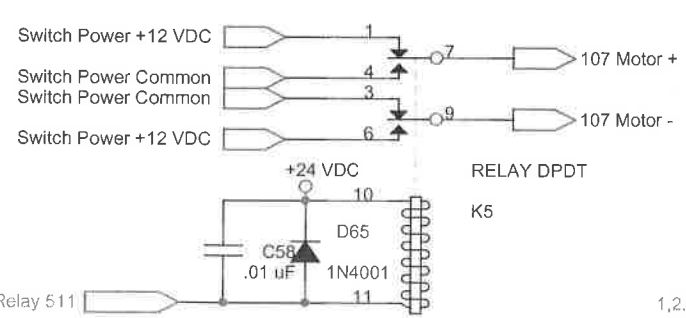

B

1,2,3,4

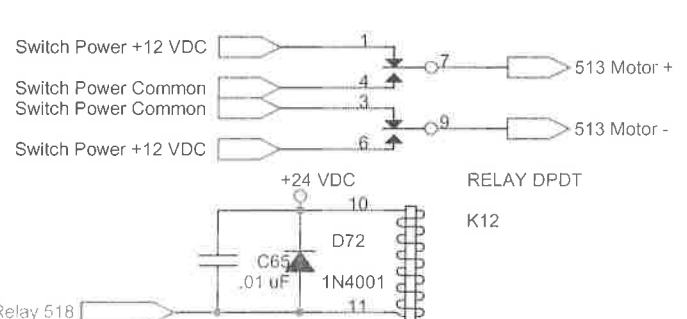
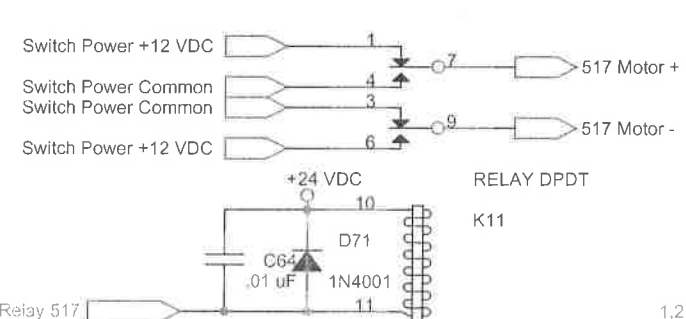
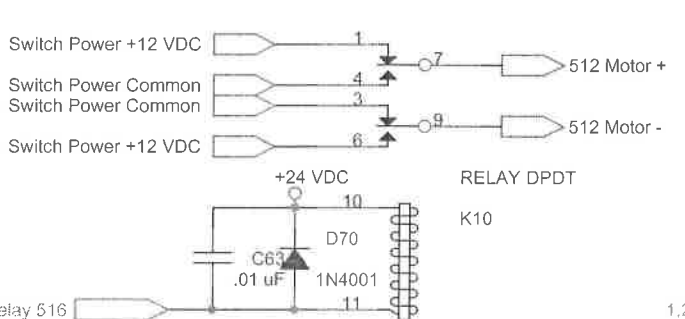
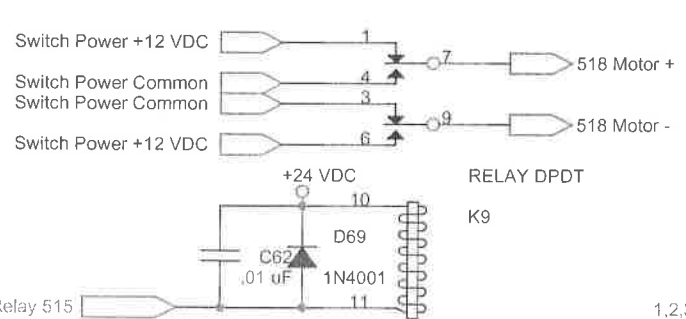

A

1,2,3,4

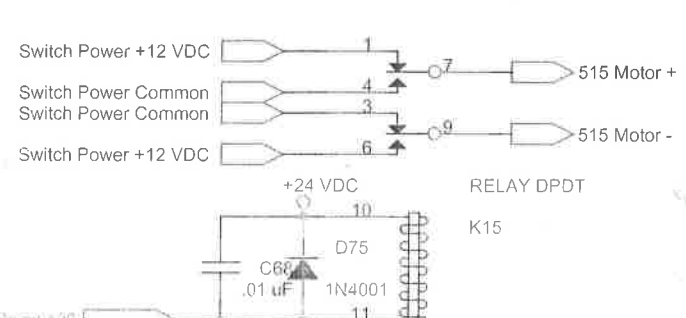
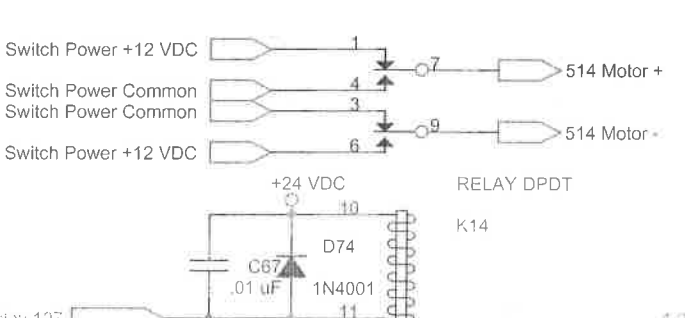
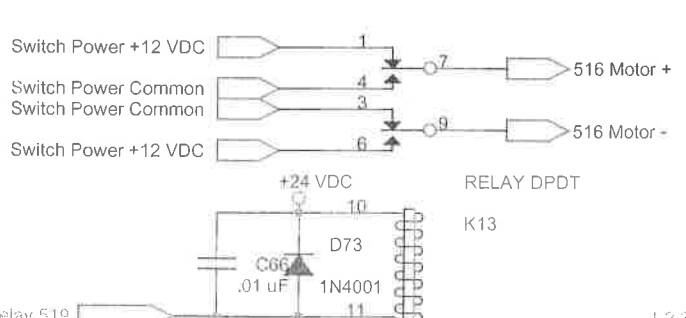

Title		
8 Switch Motor Relays		
Size	Document Number	Rev
B	Desert Yard Controls	A1
Date:	Friday, October 31, 2003	Sheet 5 of 9

- 2,3 NC Contact West Panel Loco Track 1
- 2,3 NO Contact West Panel Loco Track 1
- 2,3 NC Contact West Panel Loco Track 2
- 2,3 NO Contact West Panel Loco Track 2
- 2,3 NC Contact West Panel Loco Lead
- 2,3 NO Contact West Panel Loco Lead
- 2,3 NC Contact West Panel Yard Track 1
- 2,3 NO Contact West Panel Yard Track 1
- 2,3 NC Contact West Panel Yard Track 2
- 2,3 NO Contact West Panel Yard Track 2
- 2,3 NC Contact West Panel Yard Track 3
- 2,3 NO Contact West Panel Yard Track 3
- 2,3 NC Contact West Panel Yard Track 4
- 2,3 NO Contact West Panel Yard Track 4
- 2,3 NC Contact West Panel Yard Track 5
- 2,3 NO Contact West Panel Yard Track 5

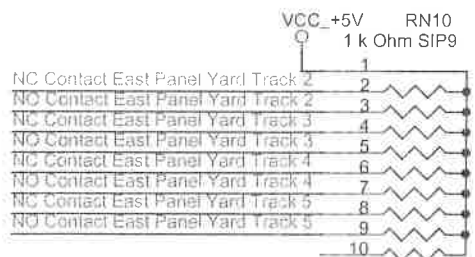
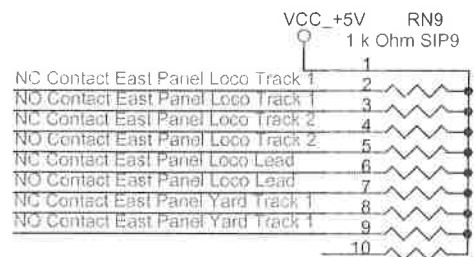
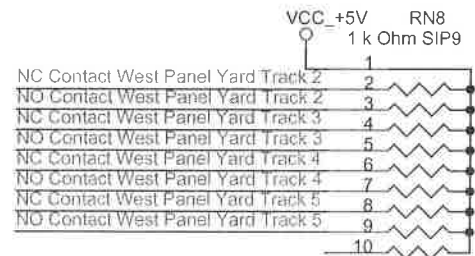
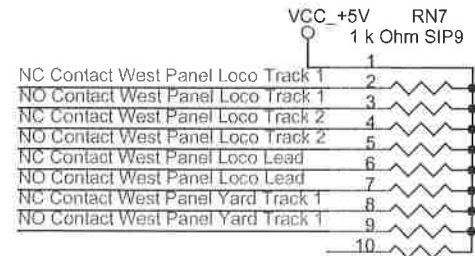

- 1,3 NC Contact East Panel Loco Track 1
- 1,3 NO Contact East Panel Loco Track 1
- 1,3 NC Contact East Panel Loco Track 2
- 1,3 NO Contact East Panel Loco Track 2
- 1,3 NC Contact East Panel Loco Lead
- 1,3 NO Contact East Panel Loco Lead
- 1,3 NC Contact East Panel Yard Track 1
- 1,3 NO Contact East Panel Yard Track 1
- 1,3 NC Contact East Panel Yard Track 2
- 1,3 NO Contact East Panel Yard Track 2
- 1,3 NC Contact East Panel Yard Track 3
- 1,3 NO Contact East Panel Yard Track 3
- 1,3 NC Contact East Panel Yard Track 4
- 1,3 NO Contact East Panel Yard Track 4
- 1,3 NC Contact East Panel Yard Track 5
- 1,3 NO Contact East Panel Yard Track 5

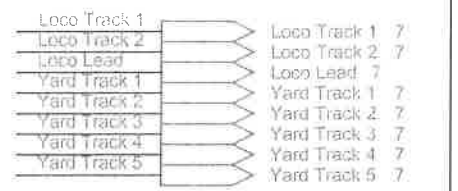
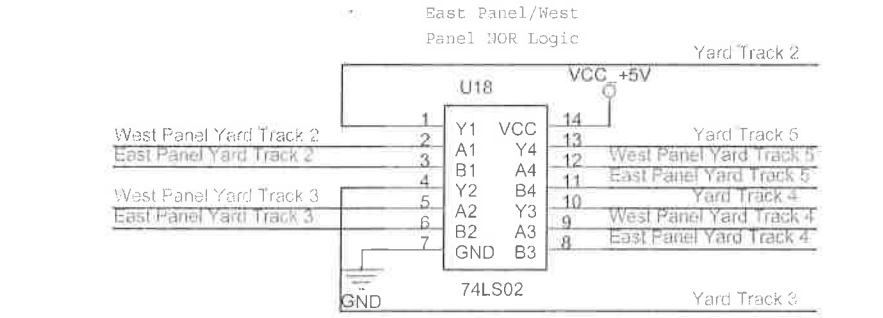
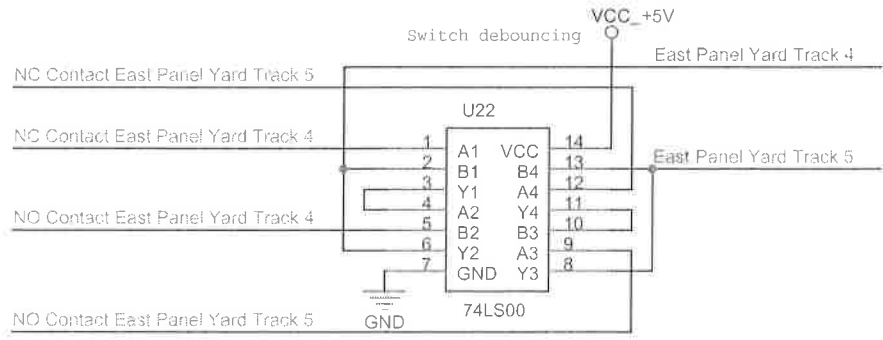
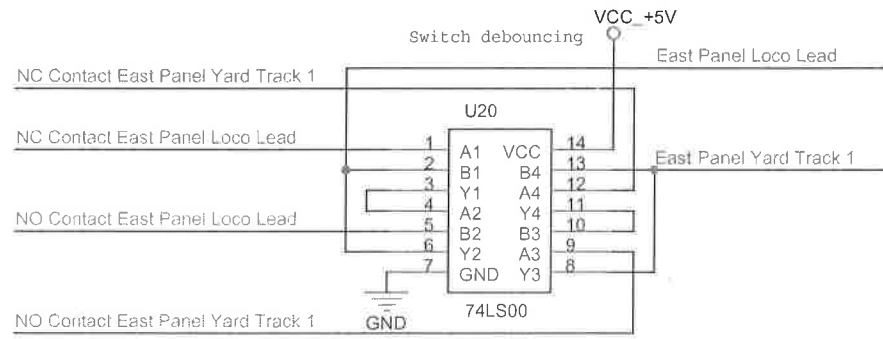
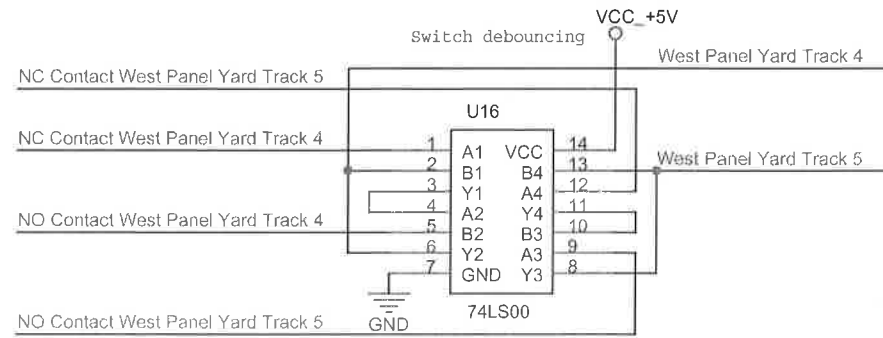
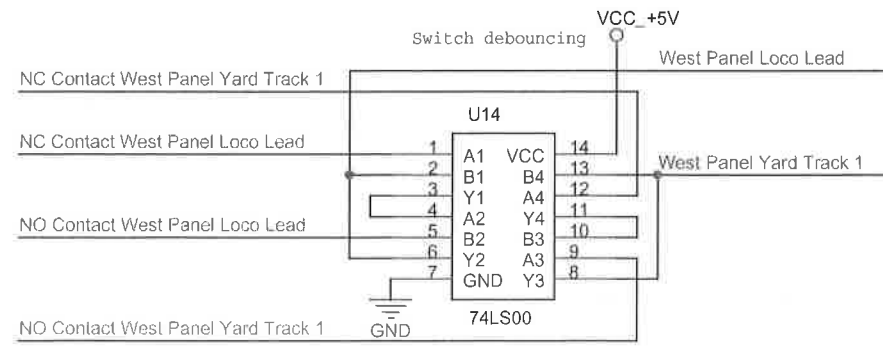
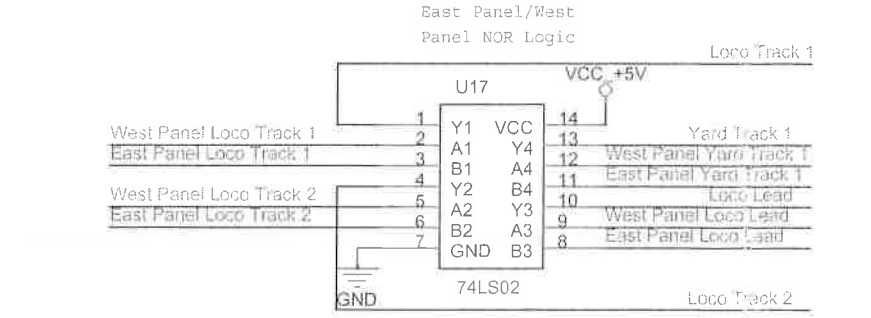
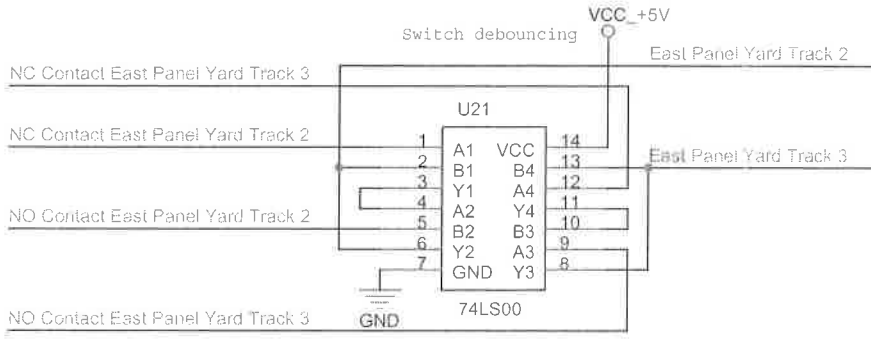
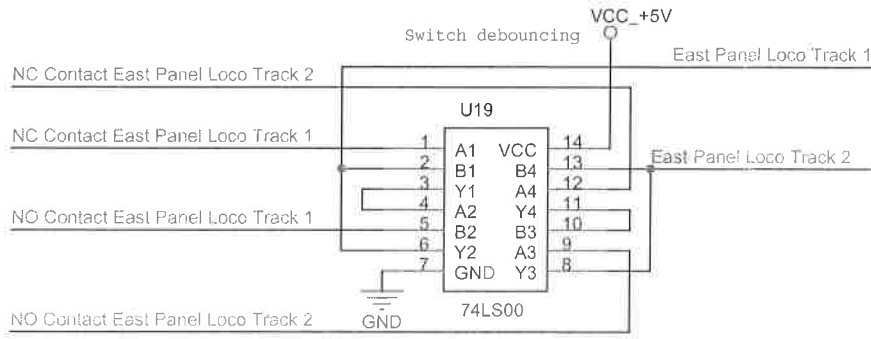
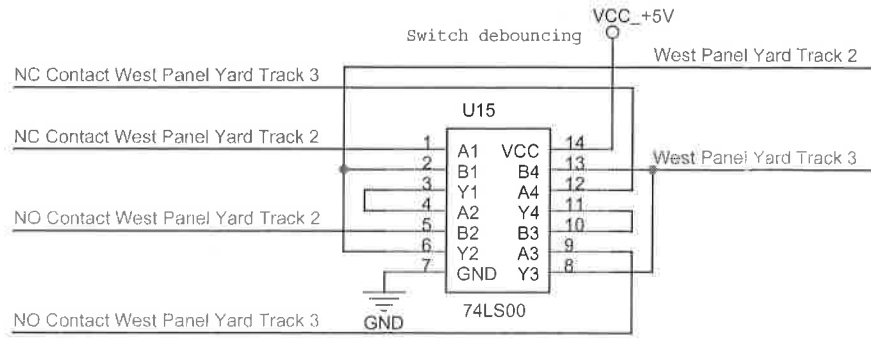
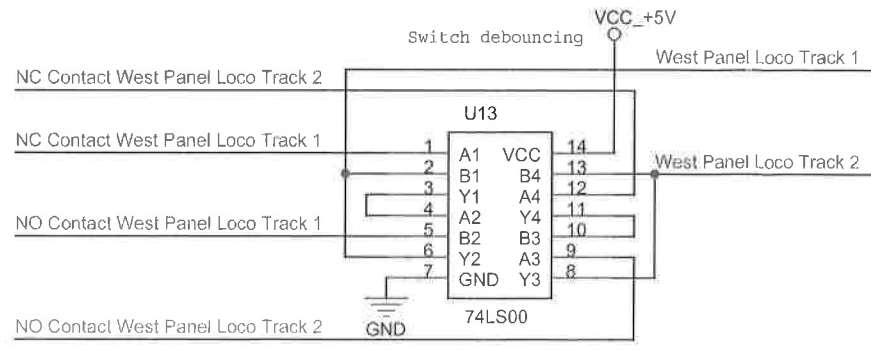

Title: 6 Track Power Switch Debouncers		
Size: B	Document Number: Desert Yard Controls	Rev: A1
Date: Friday, October 31, 2003	Sheet: 6	of: 9

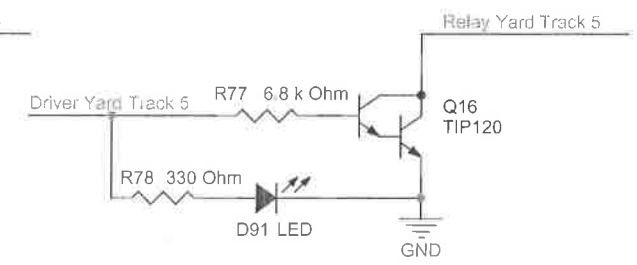
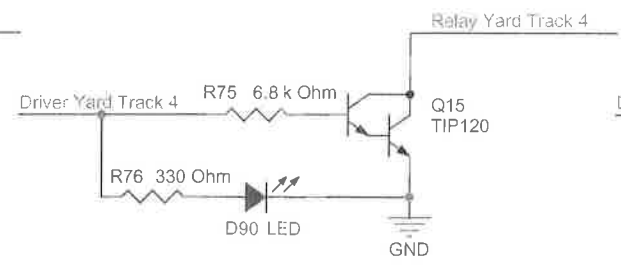
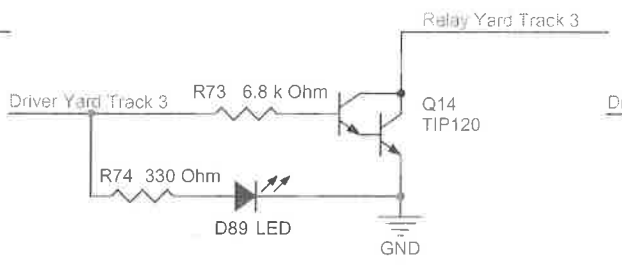
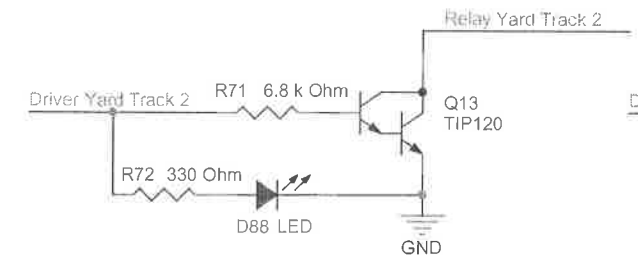
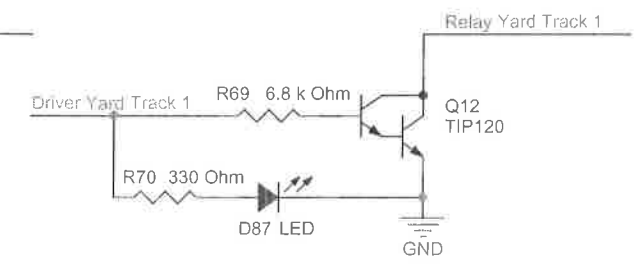
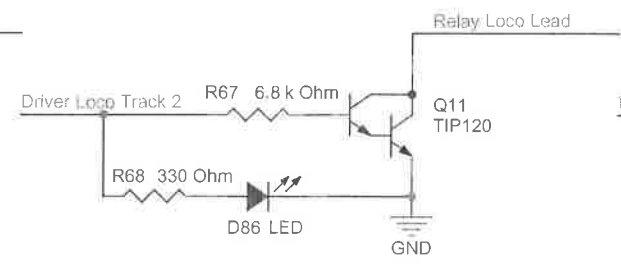
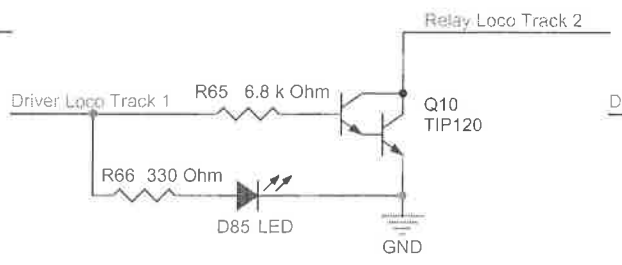
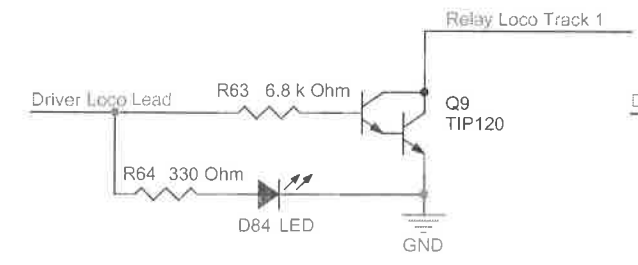
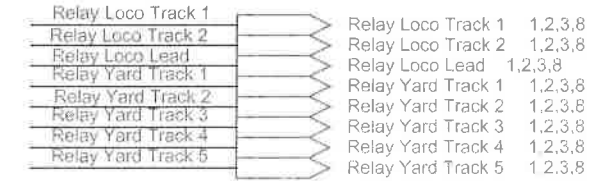
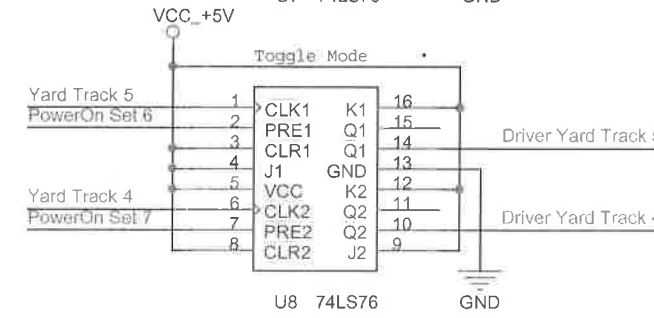
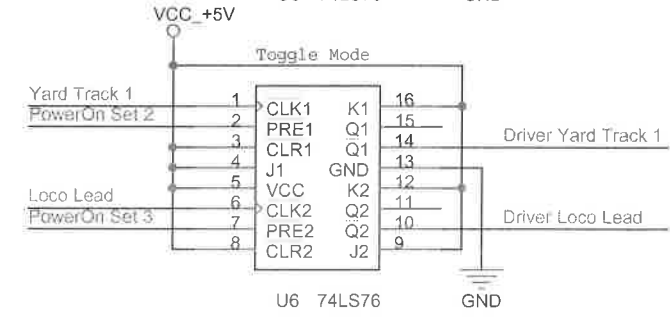
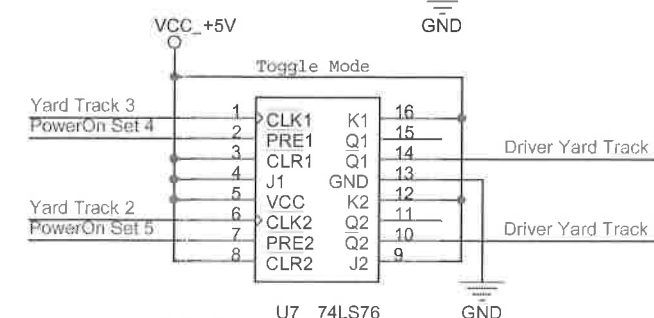
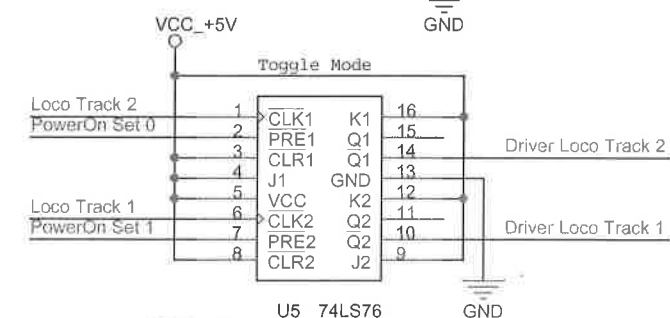
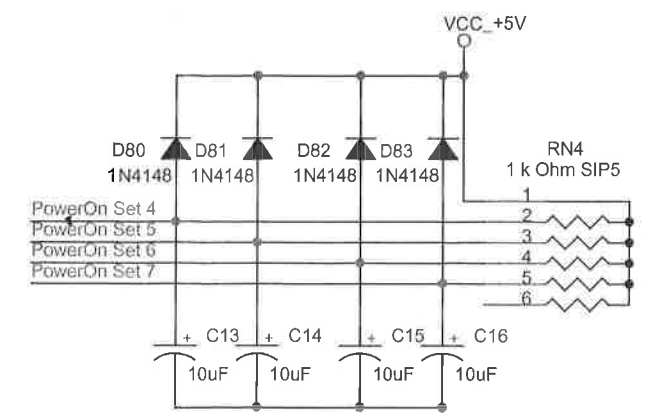
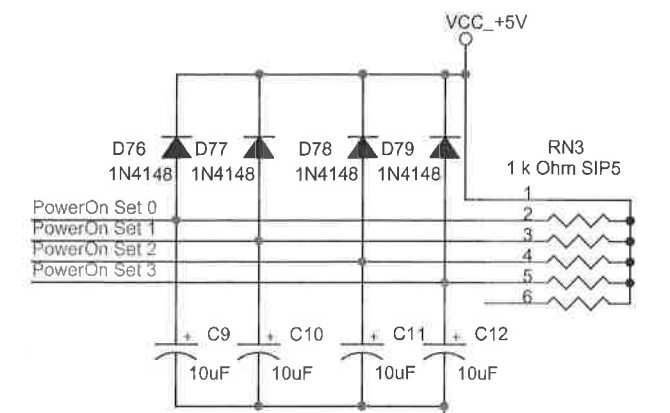
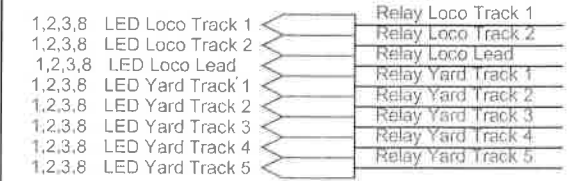
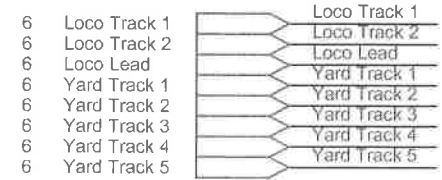

Title		
7 Track Power Logic & Drivers		
Size	Document Number	Rev
B	Desert Yard Controls	A1
Date:	Friday, October 31, 2003	Sheet 7 of 9

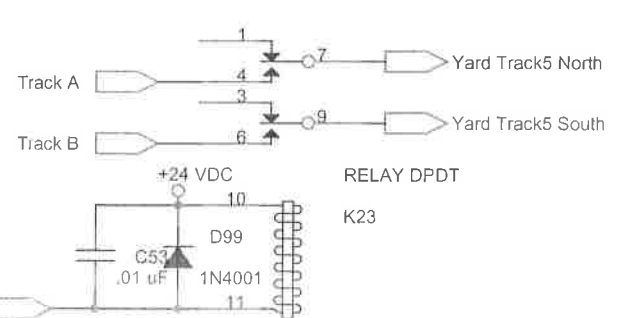
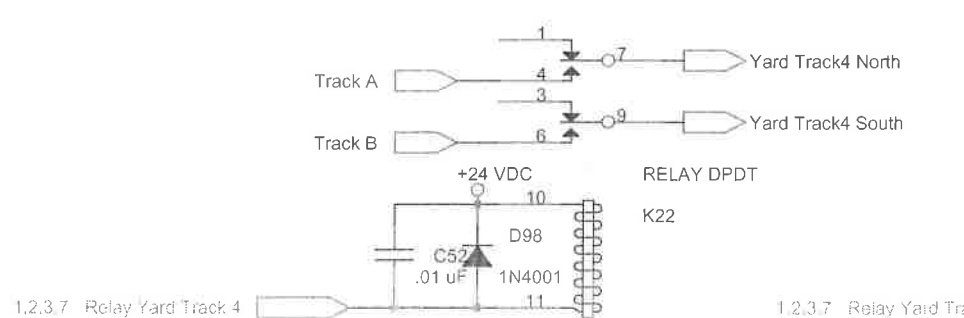
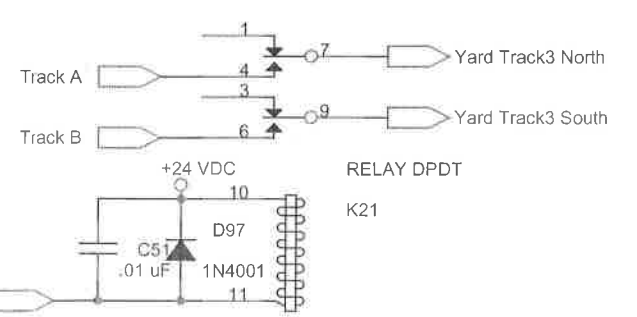
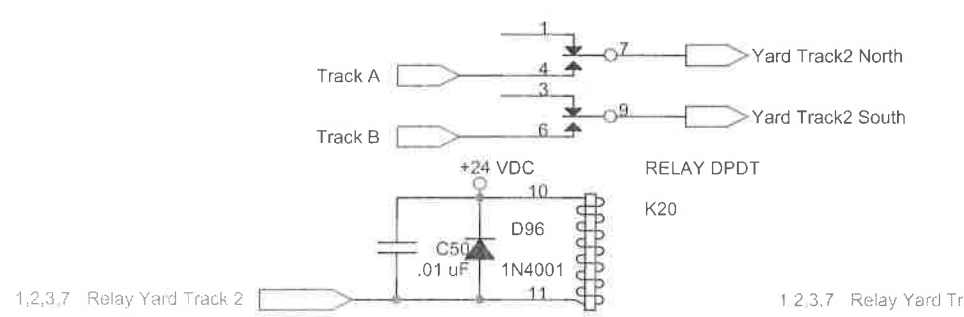
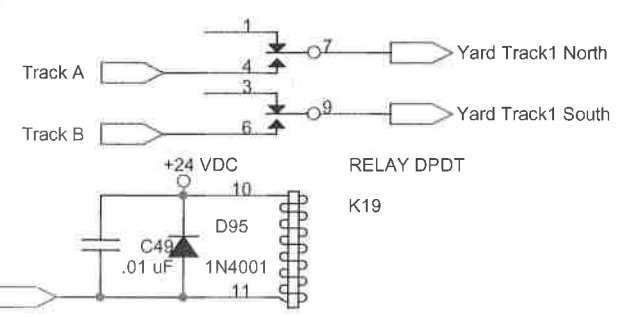
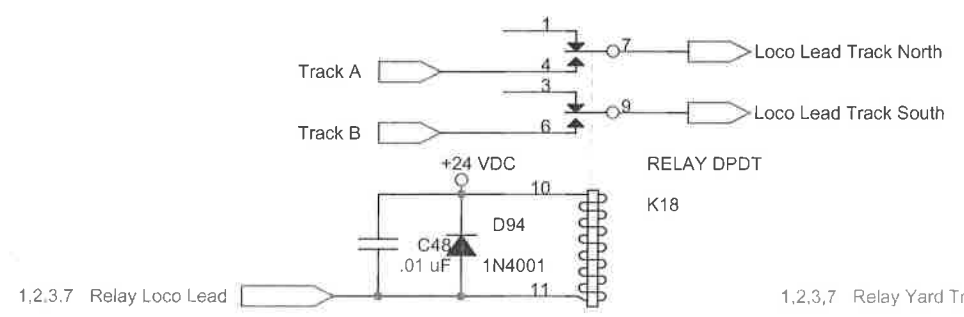
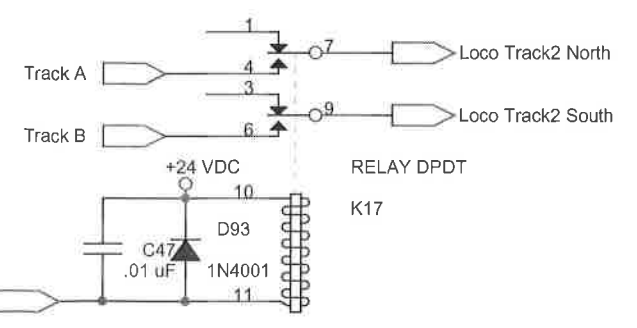
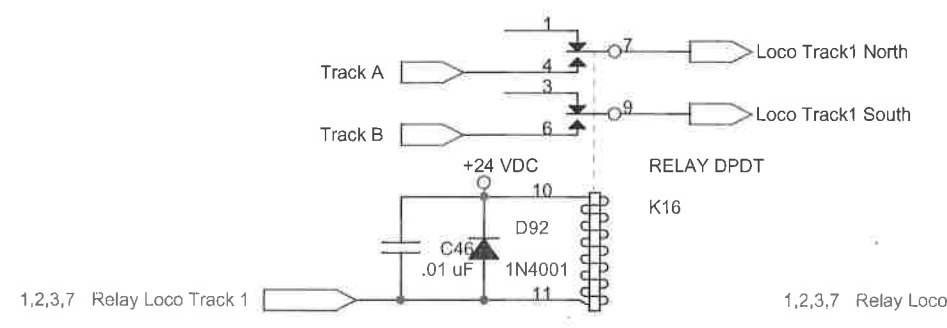

Title		
8 Track Power Relays		
Size	Document Number	Rev
B	Desert Yard Controls	A1
Date:	Friday, October 31, 2003	Sheet 8 of 9



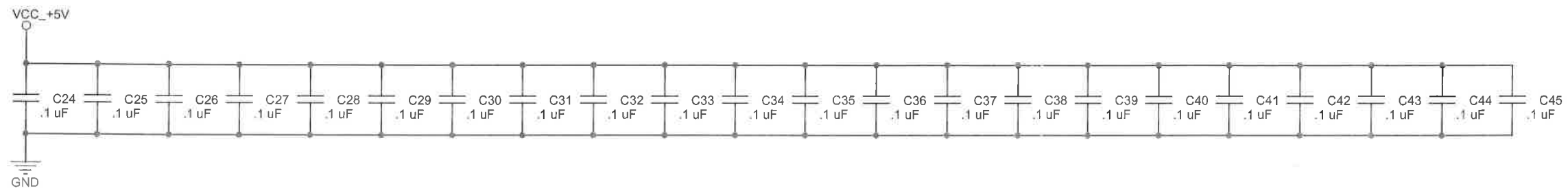

Title		
9 Caps for U1 - U22		
Size	Document Number	Rev
B	Desert Yard Controls	A1
Date:	Friday, October 31, 2003	Sheet 9 of 9