

Remote Tortoise Mount

We needed a longer cable for the remote Tortoise switch machine mount to clear two levels of bench work and to provide future access for maintenance if needed to the electronics and the switch machine.

A trip to the local Radio-Control (RC) hobby store resulted in procuring a 0.038" RC control cable, 36" in length. The internal core cable is a stranded wire – the ends were tinned with solder about 2" on either end to stiffen up the cable for adapting to the remote mount mechanism.

At the machine and actuator ends, a 1/16" drill was used to open up the clearance on the clamp that secures the cable.

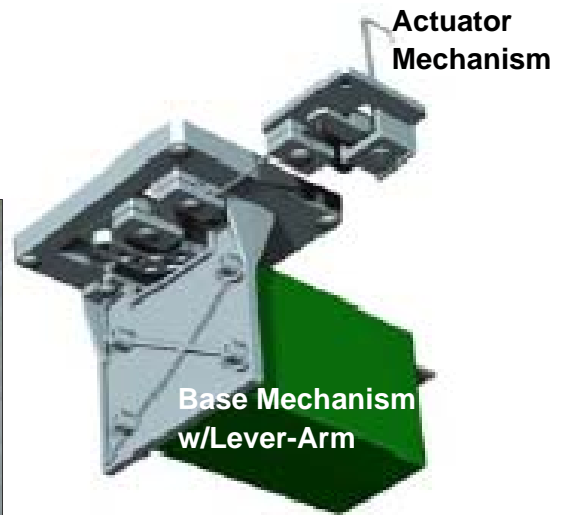

The points-actuating mechanism, mounted underneath the turnout, was modified by drilling out the hole in the crank arm with a #61 drill.



Other lessons learned include to not over-torque the screws on which the lever arm pivots in the Tortoise base as well as the cable clamps to avoid a mechanical bind.